

Modena & False Chimney Fitting Instructions

It's important that before starting, you carefully read these instructions and the instructions supplied inside the appliance. Note, the surfaces of your fireplace can be scratched or damaged if care is not taken during installation. A second pair of hands will be necessary to complete this installation safely and damage free. It is the responsibility of the installer to ensure that the correct fittings are being used to secure the product safely to the wall.

Making sure you get the right chimney height:

1. Measure the height of the room, from floor to ceiling.
2. Take away the height of the Modena suite and the height of the engine trim above the glass (915mm being the minimum, it is dependent on the adjustment height of the feet) as well as a required extra 150mm for clearance from the ceiling. This will leave you the correct height for the False chimney.

Preparing the engine:

1. Unbox and the engine and remove the packaging.
2. Unscrew the two screws on the bottom at either side of the glass.
3. Remove the glass using the provided orange gripper and take the internal packaging out with the additional boxes which contain the edge trims and fire instructions.
4. Remove the metal side panels on each side of the fire.
5. Attach the edging strips located in one of the additional boxes removed from the fire and attach all the strips to fit around three sides of the glass panels on both sides.
6. Attach the power cable and LEDs extension cable now as this can be difficult to do later. **Depending on the fire you have, the cable inputs will be on the top right on the i1500 Luminosa, and the bottom right on the i1500/i1250 Deep fire.**

Preparing the suite:

1. Lay the Modena suite on its back and screw the supplied adjustable feet in each stand.
2. Once the feet are on, stand the Modena back up and use a spirit level to adjust the feet accordingly until level.
3. Place against the wall and check the level of the suite again.
4. Slide the plinth under the Modena and clip the plinth on to the feet.
5. Lift the fire in the Modena suite and use a spirit level to make sure it is still level.

Fitting the false chimney:

1. Take the combined height of the Modena suite and engine with the false chimney and take away 39mm. this will give you the height to fit from the top of the timber hook bracket.
2. Measure 200mm inwards from the outside of the chimney breast to measure where to fit the brackets. **IT IS THE RESPONSIBILITY OF THE INSTALLER TO ENSURE THAT THE CORRECT FITTINGS ARE USED TO SECURE THE PRODUCT TO THE WALL.**
3. Lift the false chimney and place over the top of the fire and hook the top timber over the hooks.
4. Check that the fire and chimney are sitting together evenly.
5. Screw through the bottom piece of timber and into the wall to add additional security to the false chimney to stop it coming away from the wall. Both timber beams should be taking most of the weight of the chimney, as if it were to bear the weight in on the fire it could lead to damage. There should be a minimum of 8 screws through the timber to secure to the wall.
6. Attach the LED connector to the LED strip on the false chimney.

HANDLE WITH CARE WHEN MOUNTING THE SURROUND - SHARP EDGES MAY CAUSE DAMAGE TO YOURSELF AND THE SURROUND IF NOT HANDLED PROPERLY

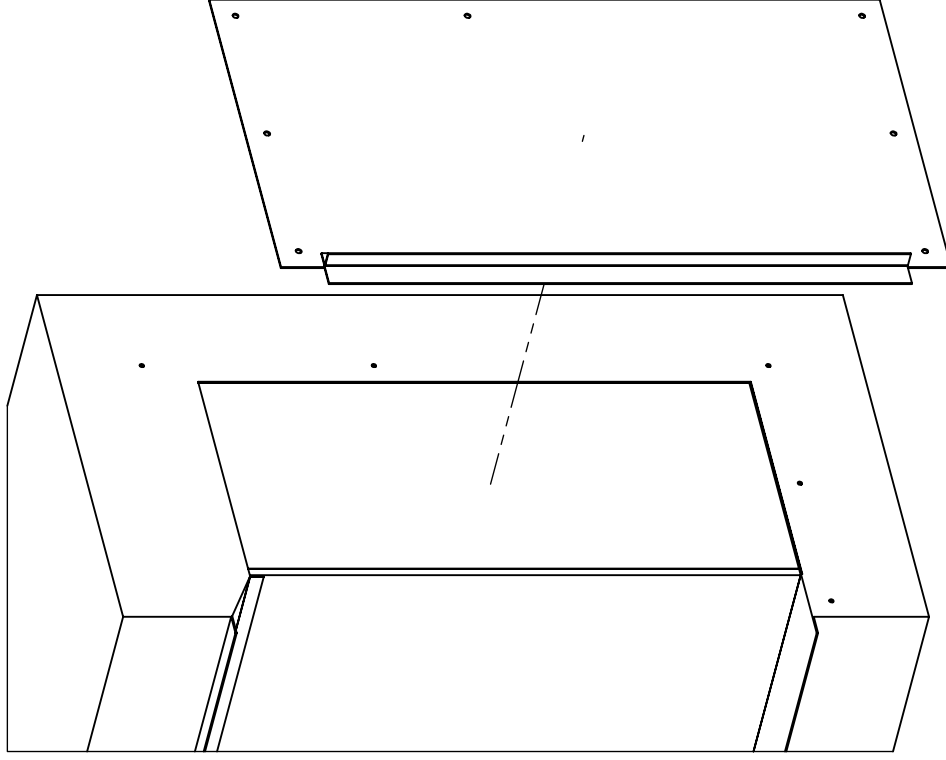

Remove the metal
side panels on the fire

Katell Ltd

Product: Modena Fitting Instructions

Copyright © Katell Ltd. All rights reserved under copyright, design and patent law. No copying of this document or item shown may be made without prior permission
Address: 478-480 Durham Way North, Newton Aycliffe, Co. Durham, DL5 6HP Te: 01325 379060 Fax: 01325 309120 Web: www.katell.co.uk E-Mail: sales@katell.co.uk

Katell
Part of
Charlton & Jorrick
ESTABLISHED 1974

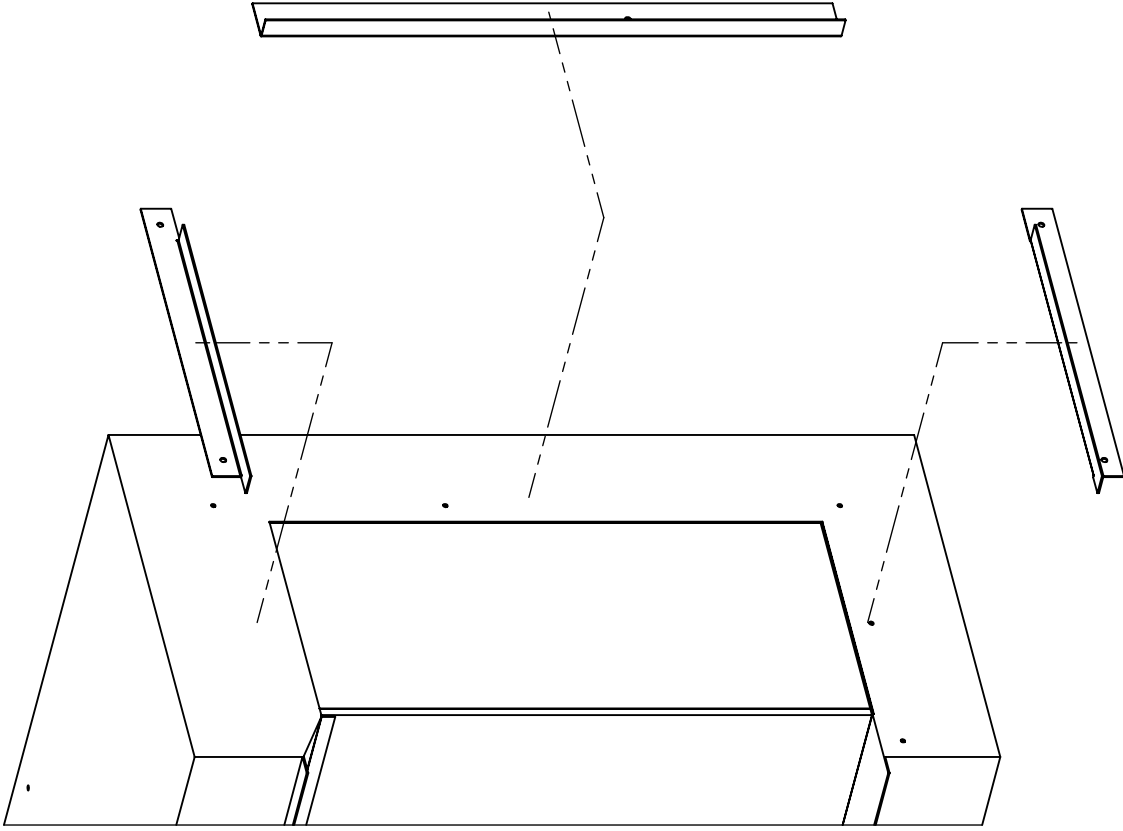

Replace the additional panels that are found in the additions inside the fire.

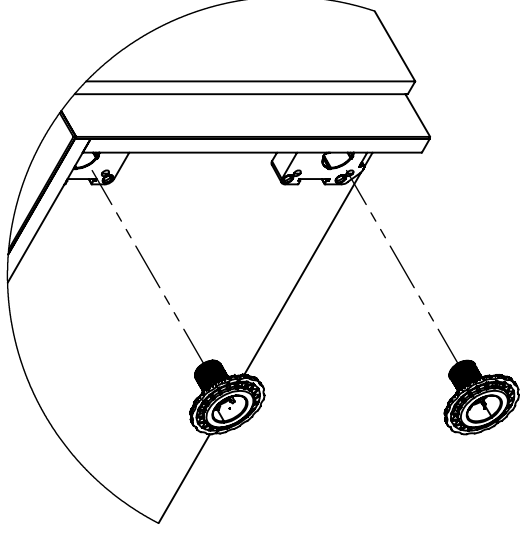
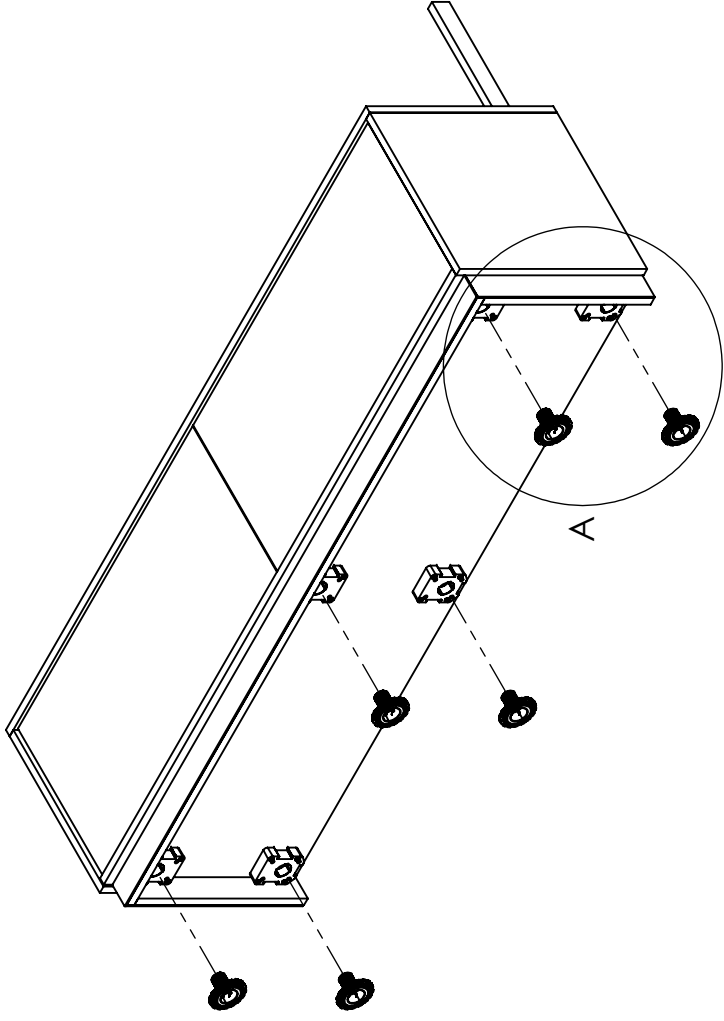

Place the Modena on its back and screw the feet in the stands on the bottom of the suite.

Katell Ltd

Product: Modena Fitting Instructions

Copyright © Katell Ltd. All rights reserved under copyright, design and patent law. No copying of this document or item shown may be made without prior permission
Address: 478-480 Durham Way North, Newton Aycliffe, Co. Durham, DL5 4HP Tel: 01325 379060 Fax: 01325 309120 Web: www.katell.co.uk E-Mail: sales@katell.co.uk

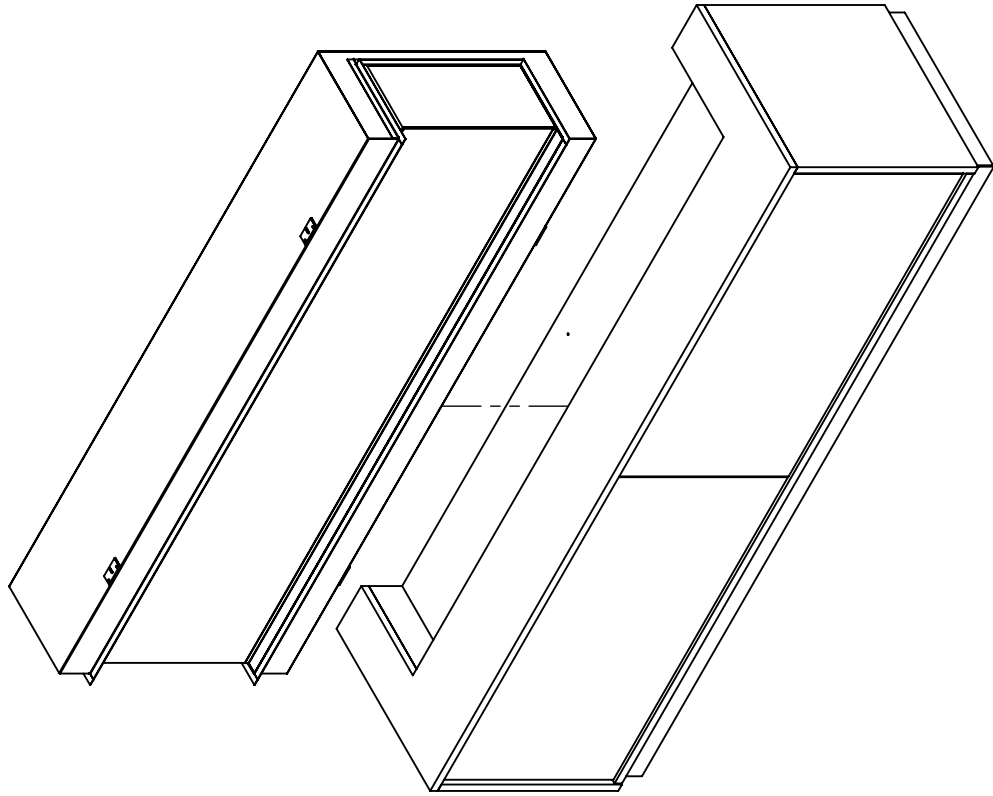

Drop the fire into the cut out on top of the Modena.

Place the side components onto the side of the fire, behind the vertical trim.

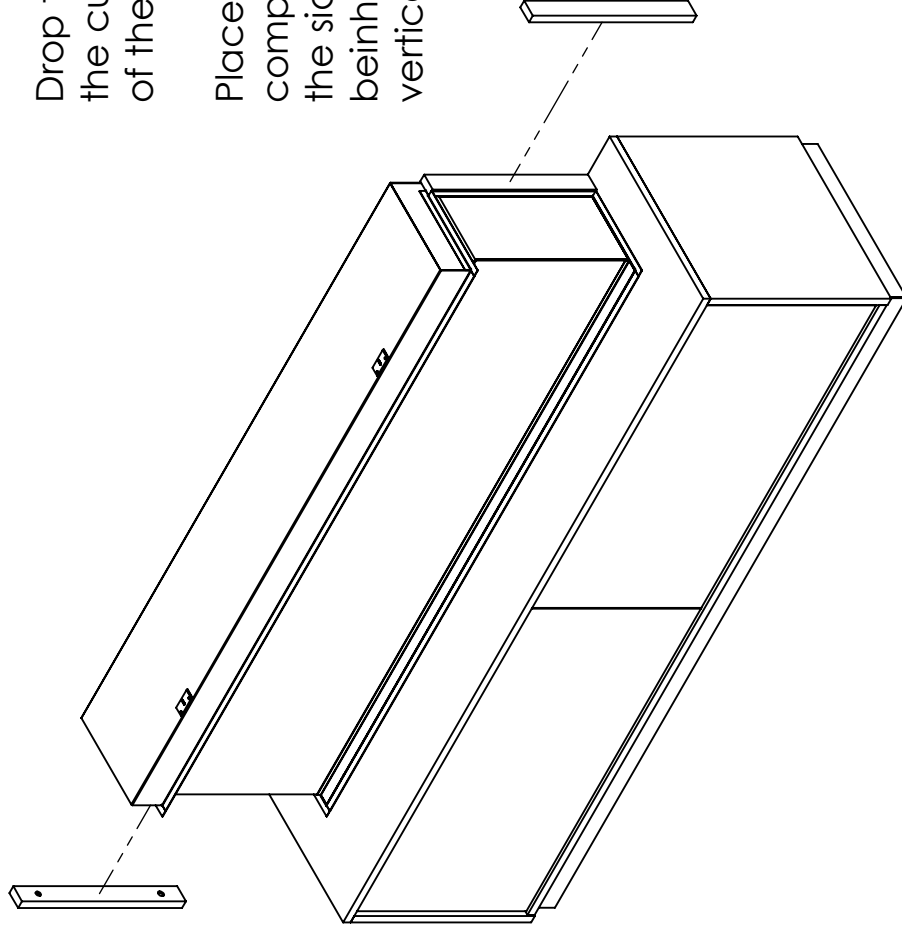

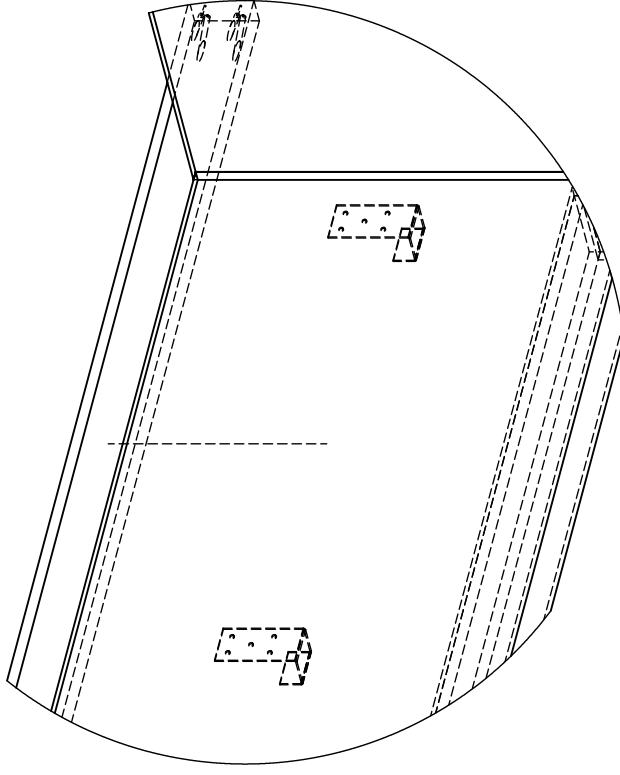
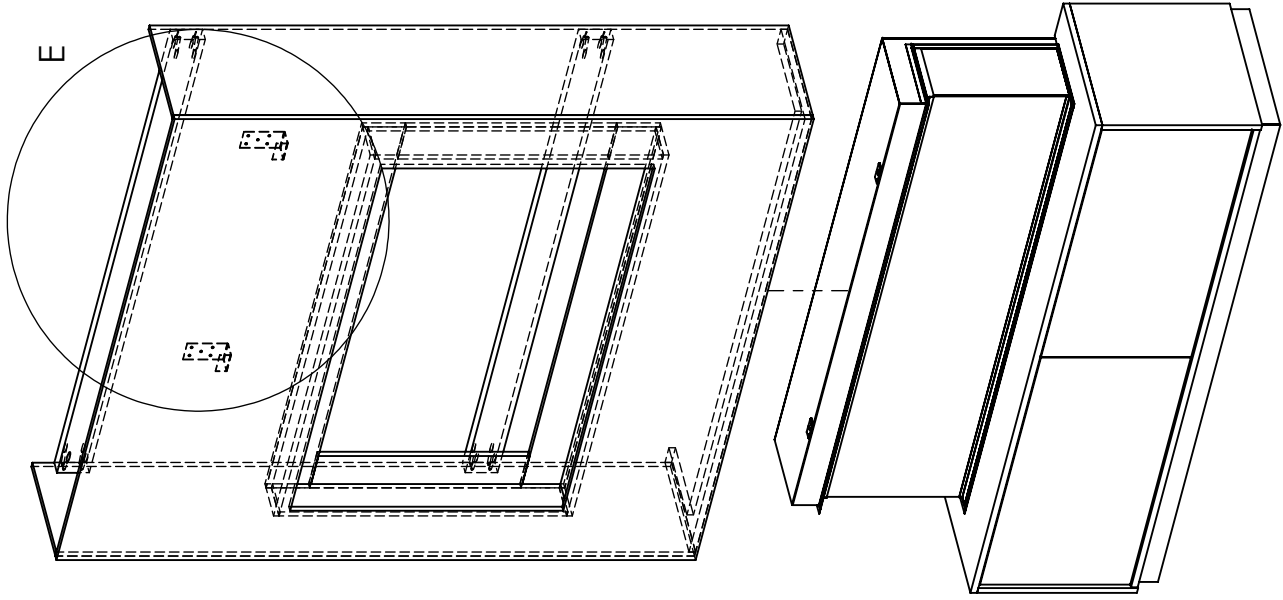

Katell Ltd

Product: Modena Fitting Instructions & False Chimney

Copyright © Katell Ltd. All rights reserved under copyright, design and patent law. No copying of this document or item shown may be made without prior permission
 Address: 478-480 Durham Way North, Newton Aycliffe, Co. Durham, DL5 6HP Tel: 01325 379060 Fax: 01325 309120 Web: www.katell.co.uk E-Mail: sales@katell.co.uk